



megamount 20 MOTO

SEMI-AUTOMATIC
TYRE CHANGER
FOR MOTORBIKE
WHEELS

5"÷25"

SINGLE
SPEED

BEAD
BREAKER



Latest generation of Hofmann Megaplan Tyre Changers, designed and manufactured in Italy. With an emphasis on build quality and ergonomics, key features such as intelligently designed turntable and super-duty automatic operation can be enjoyed as standard across all models.

megamount

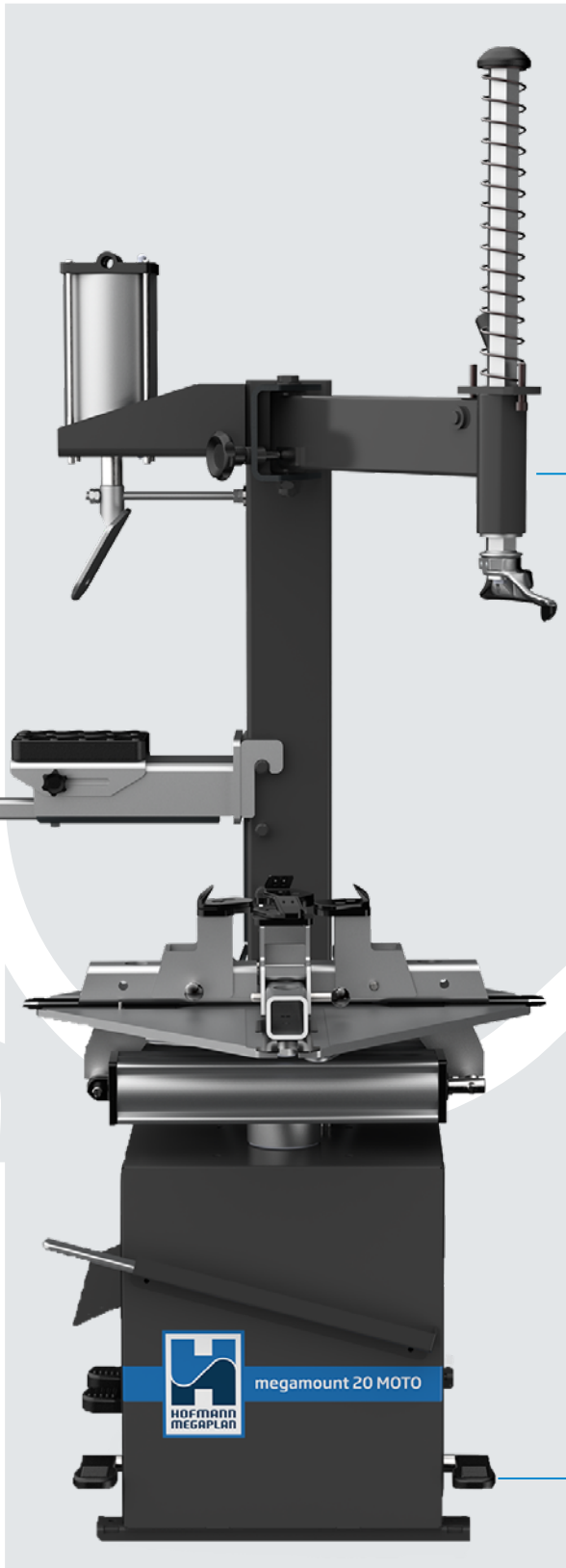

Semi-automatic tyre changer featuring a lateral swing horizontal arm and manual locking of the tool holder's vertical rod via a convenient lever positioned on top of the column. The side knob enables the operator to manually adjust the lateral position of the tool against the rim, allowing adaptation to any wheel size from 5" to 25".

Pedal unit with pneumatic controls for the bead breaker and the self-centring device, positioned on the side in an ergonomic location for the operator.

The combined system of the rotation pedal for the self-centring device enables easy operation on all three working sides of the tyre changer.

megamount 20 MOTO

SEMI-AUTOMATIC
TYRE CHANGER FOR
MOTORBIKE WHEELS

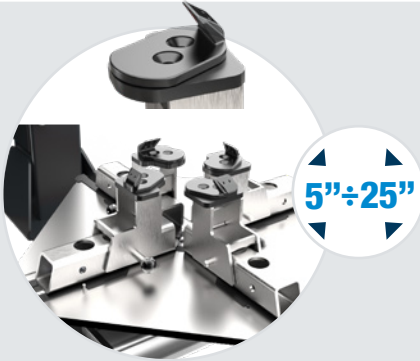

5"÷25"

Locking capacity from 5" up to 25"

The self-centring plate maintains a constant clamping force regardless of the rim diameter. Thanks to two quick and easy adjustment positions, it allows smooth operation on rims from 5" to 25".

The ergonomically designed clamps ensure a secure grip, even on wheels with tyres that have a pronounced shoulder.



BEAD
BREAKER

Pneumatic bead breaker

The pneumatic bead breaker, equipped with a double-acting cylinder and a horizontal bead removal system, ensures constant control throughout all working phases and allows the operator to maintain a comfortable standing position at all times.

Single speed system

Single speed 400V/50-60Hz/3ph motor controlled by pedal.

SINGLE
SPEED

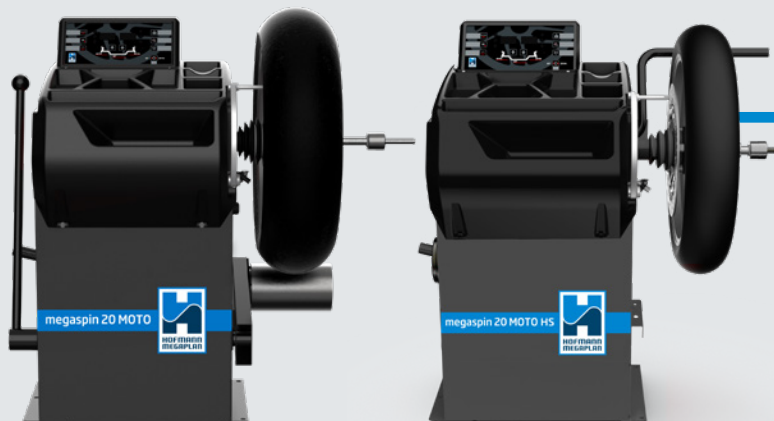

megaspin20 MOTO - megaspin20 MOTO HS

Hofmann suggests the combination with the motorcycle wheel balancers *megaspin 20 MOTO* - *megaspin 20 MOTO HS*

Optional accessories



Removable and horizontally adjustable wheel support

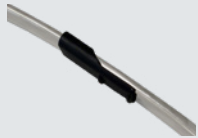

WDK plastic protection for curved run-flat lever



Plastic protection for lever



Set of 10 plastic protections for lever



Plastic rim protector

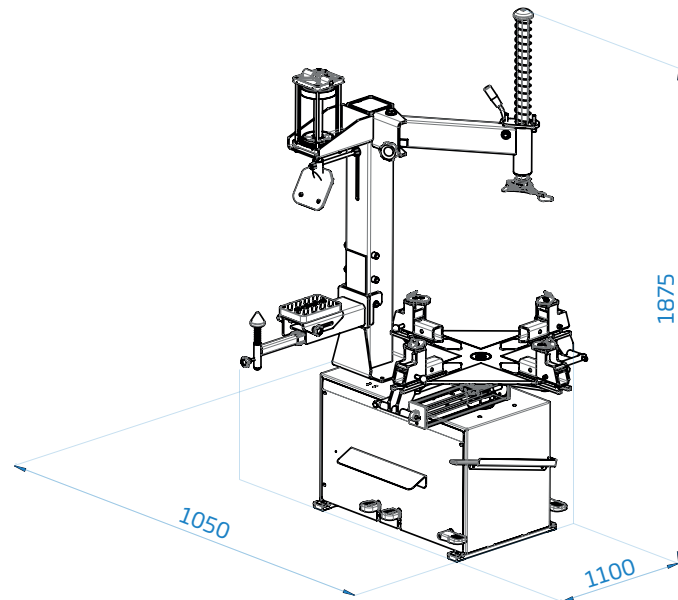

Technical data

Clamping capacity	5" - 25"
Max wheel diameter	1000 mm (39.5")
Max wheel width	370 mm (14.5")
Bead breaker force	1100 kgf
Turntable speed	8 rpm
3-Phase motor	0.55 kw
Operating pressure	8-10 bar (116-145 psi)
Noise level	< 70 ± 3 dB (A)
Net weight	190 kg



HOFMANN MEGAPLAN GmbH
 Hüttenstrasse 7 - 67550 Worms - Germany
 T +49 (0)6242 913 6666
 hm-mail@hofmann-megaplan.com
 www.hofmann-megaplan.com