

# *megamount matic*



## Super Automatic – Robotic Tyre Changer

That is self-evident for us:

- Roller bead breaking system
- Rim clamping from 10" up to 34" inches
- Maximum rim width 16 inches
- Maximum tyre diameter 1200 mm
- Filter with pressure regulator and manometer for 10 bar
- Inflating pressure limiting device 3,5 bar (CE)
- Power supply 400V 3ph

The competition might not have this:

- Patented wheel lift system
- Laser pointers to set up the right position of the tyre.
- Center post wheel centering and locking system.
- Rotating double tool with mechanical locking system.
- Control system by pedals and joystick for easy and intuitive working



For all problems the right solution:

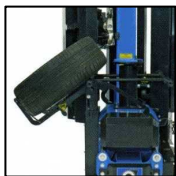

- WHEEL LIFT

Patented wheel lift system lifts the tyre automatically into the centering position over the clamping chuck.

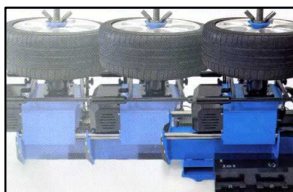

- CENTER POST  
WHEEL CENTERING

Chuck carriage, automatically slides back and forth to set up the working position for any kind of passenger car tyre from 10" up to 34".

- CENTER POST  
WHEEL CLAMPING

Center post wheel centering and locking system by cones and flange, extremely easy and fast, with tracking pin to avoid rim sliding over the flange plate.



- LASER POINTERS

To set up the right position of the tyre before starting operations. Once the position is fixed through the pointers, all functions are automatic in a sequence.

- ROLLER BEAD  
BREAKER

System to loosen upper and lower bead with no damage or risk and high precision.



- CONTROL SYSTEM** By pedals and joystick; ergonomic and user-friendly, gives the operator a very easy, handy and intuitive working way. Every joystick movement is automatic, once the tyre position is fixed.

**This comes with the machine:**



- Plastic Protectors for special types of RUNFLAT tyres, cones etc.

**Main Options:**



- Special adaptor to clamp wheels without center hole and clamping in reverse position. For 3,4,5 and 6 holes. Option: longer fingers with cones, normal length fingers with round head.



- Arm with plastic fitting head for soft tyres and small wheels. To operate without setting up the tyre position for automatic operation. Operation with lever.

Technical Data	
Operating pressure	8 to 10 bar
Three-phase motor	400 V / 3 ph
Wheel lift capacity	80 kg
Rim clamping	10 - 34 inches
Bead breaker force	14406 N
Max wheel diameter	47" (1200mm)
Max rim width	16" (406mm)
Dimensions, packed (WxDxH)	1350x2000x1900 mm
Gross weight, packed	545 kg

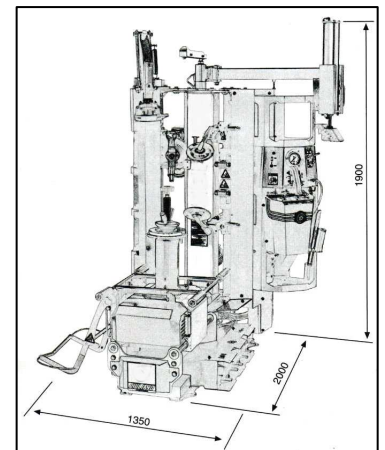

HOFMANN MEGAPLAN GMBH  
 Hauptstraße 67  
 A-5302 Henndorf · Austria  
 Tel: +43-6214-646612 Fax - 646622  
[hm-mail@hofmann-megaplan.com](mailto:hm-mail@hofmann-megaplan.com)  
[www.hofmann-megaplan.com](http://www.hofmann-megaplan.com)