

megamount 851-2



Heavy duty tyre changer with a 90 degree angle between chuck and tool. For trucks, agricultural and earthmoving vehicles.



This is self-evident for us:

- Movable control
- 2 speed rotation chucking table and tools holder
- Adjustable working pressure
- Clamping range 14" –56"
- Tyre width maximal 1.500 mm (57")
- Tyre diameter maximal 2500 mm (96")

For all problems the right solution :

- **INTEGRAL MOVEMENT** Chuck holder and tool holder always work on the same plane, for a perfect angle of the operating tool against tyre bead.
- **CONTROL UNIT** The movable control unit allows the operation out of any position
- **WORKING SPEED** Two speeds ensure a quick operation without damaging tyre and rim
- **CLAMPING HEAD** The hydraulic pressure of the rim clamping can be adjusted. So any damage of the rim is avoided.
- **FULLY AUTOMATIC FUNCTIONS** All movements of the machine are fully automatic. This ensures the most easy, and also the most safe handling of all functions

This comes with the machine



Technical Data	
Clamping Range	14"-56"
Max. wheel weight	2000 kg
Max. wheel diameter	2500 mm (96")
Max. wheel width	1500 mm (57")
Hydraulic pump motor	3 kW 400 V-3PH
Gearbox motor	1,5 – 2,3 kW 400 v-3PH
Operating pressure	0 - 160 bar
Bead breaker force inside-outside	3.364 kg
Noise level in working condition	< 70 db
Net weight	1.300 kg
Dimensions	W. 3.150 x D. 2.600 x H. 1.970 mm

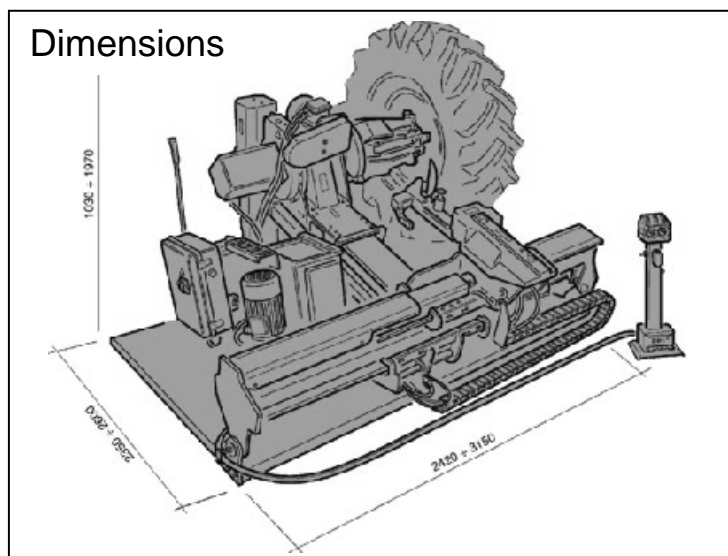

HOFMANN MEGAPLAN GMBH
 Hauptstraße 67
 A-5302 Henndorf · Austria
 Tel: +43-6214-646612 Fax - 646622
hm-mail@hofmann-megaplan.com
www.hofmann-megaplan.com