

# *megamount* 503e



**Automatic tilt back with 24" tabletop**

**High End European design combined with low end production costs**

**Low cost tyre changer for petrol stations and car garages**

That is self-evident for us:

- Pneumatic forward/back swinging mounting arm
- Pneumatic locking mounting head.
- Up and down movement of operating arm by spring
- 2 clamping cylinders
- Rim clamping inside 12 – 24 inches, outside 10 - 20 inches
- Maximum rim width 14 inches
- Maximum tyre diameter 1100 mm
- Megafit 2 help- and press arm (Option)
- Operating pressure limiting device 10 bar
- Inflating pressure limiting device 3,5 bar (CE)

For all problems the right solution:

- **MOUNTING ARM**                      Tiltable forth and back pneumatically.
- **MOUNTING SHAFT**                Pneumatic locking. Automatically keeping distance off the rim when blocked.
- **MOUNTING HEAD**                Optimised profile for high efficiency when working with different dimensions of tyres and rims.
- **BEAD BRAKER**                    Strong one way power cylinder 3 tons. Special contoured flexible blade for easy, ergonomic working.
- **CLAMPING SYSTEM**              Self-centring four jaw chuck clamping power. Two turning directions. Adjustable clamps for more flexibility.

This comes with the machine:

- Air pressure lubricator
- Grease holder
- Tyre lever
- Protection Set A
- 10 bar working pressure limiting device
- CE 3,5 bar inflating pressure limiting device

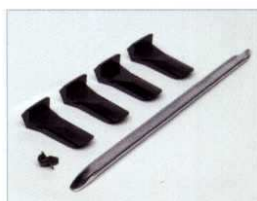

## Options: intelligent and universal

Standart inflating pistol



Motorcycle clamps



Tubeless inflating device

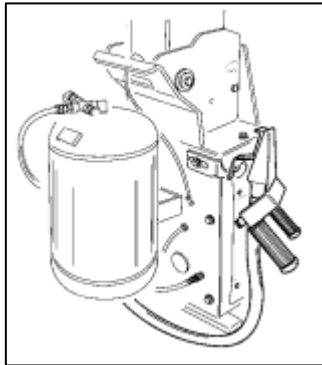

Double Act Helparm Megafit 2

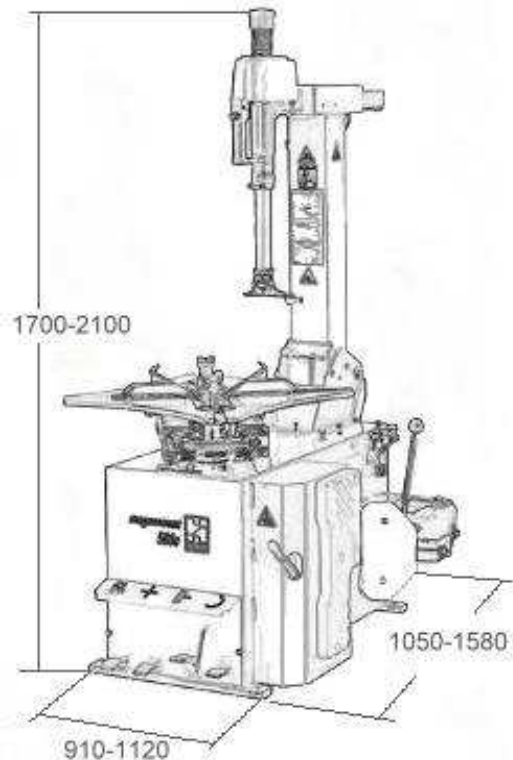
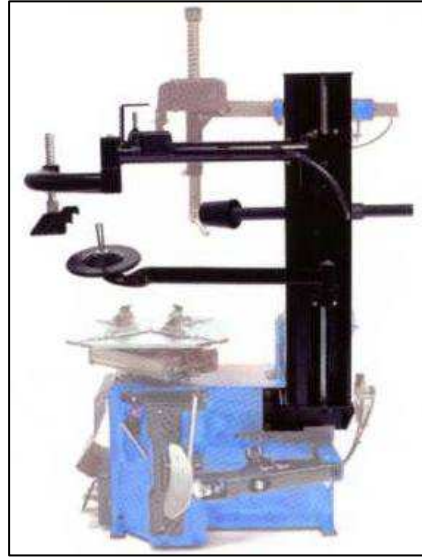

### Technical Data

Compressed air supply	10 bar
Three-phase motor	230 - 400 V / 50 Hz / 550 W
limited Inflating pressure	3,5 bar
Rim clamping	10-24 inches
Max wheel diameter	1100mm/43 inches
Max tyre width	356mm /14 inches
Bead braker pressure	3000 kg
Gross weight, packed	235 kg



HOFMANN MEGAPLAN GMBH  
Hauptstraße 67  
A-5302 Henndorf · Austria  
Tel: +43-6214-646612 Fax - 646622  
[hm-mail@hofmann-megaplan.com](mailto:hm-mail@hofmann-megaplan.com)  
[www.hofmann-megaplan.com](http://www.hofmann-megaplan.com)