

# ***megamount VANGUARD*** **AUTOMATIC-FLAG**

The first Automatic multi speed flag arm with solid and compact design in the market to handle the toughest low profile/alloy rim combinations and run flat tyres with UniClamp® patented turntable, and electric bead breaker.



## **MAIN FEATURES**

- Flag design for operation in narrow spaces
- Quick manual fine adjusting mounting arm
- UniClamp® - system with single flange
- Clamping range 10"- 26" inches \*
- Balanced force on self lubricating rollers clamps
- EBB® Electric bead breaker
- Multi speed Motor inverter turntable with pedal control
- Reversible rubber pad
- Ergonomic side pedals operation

**MADE IN EU** Designed, and manufactured in ITALY  
5 Patents pending®



Optional Spider Assist 1 press system



### **UniClamp®**

This unique and patented ultra strong turntable design incorporates the patented UniClamp® system with guides that are moving on self lubricated rollers, with single flange, providing a balanced, and straight 10" to 26" clamping range without adjustment. 3 Years Warranty on the UniClamp® system.

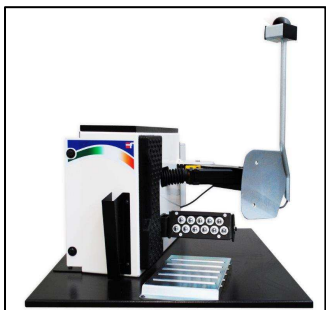

With standard side & floor rollers

### **EBB® - Electric Bead Breaker**

The EEB motor inverter powered system, allows to control with millimetre precision the bead breaking phase, avoiding unnecessary movement of the blade forth-backward. Finger operated multi pressure switches. Smooth and noiseless operation. This eliminates the problem with the blade getting stuck between the rim and tyre.



### **QTC® - Quick Tool Change**

To enable fast, tool-free interchange between demount heads. Includes standard-low profile, and plastic heads.



### **Wee-Rollers®**

Prevents the wheel from slipping backwards but supports the rolling movement.



### **Floor Rollers**

Solid built floor rollers, enables the operator to easily roll the wheels when bead breaking

#### Standard accessories coming with the machine:



- Oiler with manometer
- Grease pot holder
- Tyre lever
- Pedal inflating
- 10 bar operating pressure limiting device
- Air pump for inflating with CE 3,5 bar pressure limiting device
- Plastic protection package

#### Optional Accessories



##### Spider Assist 1 ®

This is the space saving patented evolution of similar design, optimal for handling run-flat tyres. Twin assist arms provide twice the handling power. Also enables both arms to operate independently of each other. The innovative Spider-design allows great space saving, and even small tire shop can fit it.



##### Mega Bazooka

This device helps seat the bead of stubborn sidewalls when inflating. Mobile unit with possibility to be integrated in the machine.

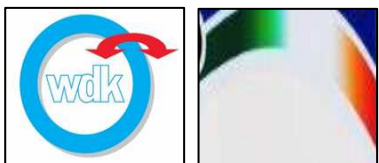

##### WDK-KIT

to provide full WDK compatibility.

##### Colour Options

Special colours on demand for minimum quantity

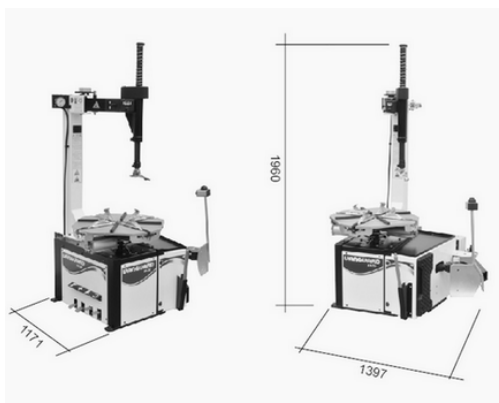

<b>TECHNICAL DATA</b>	
Air pressure	8 to 12bar
Main Motor inverter	230V / 50Hz / 750W
Bead breaker motor	230V / 50Hz / 750W
Self-centring lock	12"-26"
Maximal wheel diameter	1000mm (39")
Maximal rim width	335mm (13")
Bead breaker pressure	1600kg (electric)
Rotation speed	From 8 to 18 rpm
Dim.(WxDxH) 703 XLE	135x112x205 (cm)
Gross weight (packed)	407kg